

ELMO

CEILING PRESENTER

HV-C1000XG

INSTRUCTION MANUAL

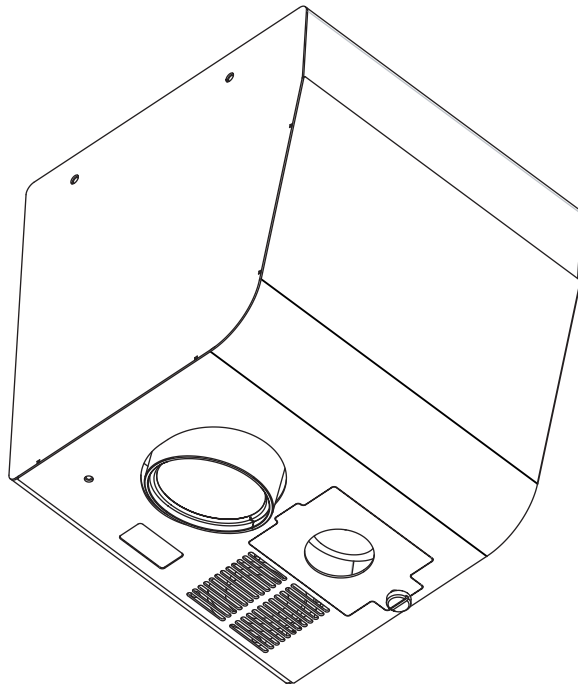

Please read this instruction manual carefully before using this product and keep it for future reference.



IMPORTANT SAFEGUARDS

- **Read Instructions** – All the safety and operating instructions should be read before the appliance is operated.
- **Retain Instructions** – The safety and operating instructions should be retained for future reference.
- **Heed Warnings** – All warnings on the product and in the operating instructions should be adhered to.
- **Follow Instructions** – All operating and use instructions should be followed.
- **Cleaning** – Unplug this product from the wall outlet before cleaning. Do not use liquid cleaners or aerosol cleaners. Use a damp cloth for cleaning.
- **Attachments** – Do not use attachments not recommended by the product manufacturer as they may cause hazards.
- **Water and Moisture** – Do not use this product near water - for example, near a bath tub, wash bowl, kitchen sink, or laundry tub, in a wet basement, or near a swimming pool, and the like.
- **Accessories** – Do not place this product on an unstable cart, stand, tripod, bracket, or table. The product may fall, causing serious injury to a child or adult, and serious damage to the product. Use only with a cart, stand, tripod, bracket, or table recommended by the manufacturer, or sold with the product. Any mounting of the product should follow the manufacturer's instructions, and should use a mounting accessory recommended by the manufacturer.
- **Ventilation** – Slots and openings in the cabinet are provided for ventilation and to ensure reliable operation of the product and to protect it from overheating, and these openings must not be blocked or covered. The openings should never be blocked by placing the product on a bed, sofa, rug, or other similar surface. This product should not be placed in a built-in installation such as a bookcase or rack unless proper ventilation is provided or the manufacturer's instructions have been adhered to.
- **Power Sources** – This product should be operated only from the type of power source indicated on the marking label. If you are not sure of the type of power supply to your home consult your appliance dealer or local power company. For products intended to operate from battery power, or other sources, refer to the operating instructions.

■ **Grounding or Polarization** – This product may be equipped with either a polarized 2-wire AC line plug (a plug having one blade wider than the other) or a 3-wire grounding type plug, a plug having a third (grounding) pin. The 2-wire polarized plug will fit into the power outlet only one way. This is a safety feature. If you are unable to insert the plug fully into the outlet, try reversing the plug. If the plug still fails to fit, contact your electrician to replace your obsolete outlet. Do not defeat the safety purpose of the polarized plug. The 3-wire grounding type plug will fit into a grounding type power outlet. This is a safety feature. If you are unable to insert the plug into the outlet, contact your electrician to replace your obsolete outlet. Do not defeat the safety purpose of the grounding type plug.

■ **Power-Cord Protection** – Power-supply cords should be routed so that they are not likely to be walked on or pinched by items placed upon or against them, paying particular attention to cords at plugs, convenience receptacles, and the point where they exit from the product.

■ **Lightning** – For added protection for this product during a lightning storm, or when it is left unattended and unused for long periods of time, unplug it from the wall outlet and disconnect the antenna or cable system. This will prevent damage to the product due to lightning and power-line surges.

■ **Overloading** – Do not overload wall outlets, extension cords, or integral convenience receptacles as this can result in a risk of fire or electric shock.

■ A product and cart combination should be moved with care. Quick stops, excessive force, and uneven surfaces may cause the product and cart combination to overturn.



■ **Object and Liquid Entry** – Never push objects of any kind into this product through openings as they may touch dangerous voltage points or short-out parts that could result in a fire or electric shock. Never spill liquid of any kind on the product.

■ **Servicing** – Do not attempt to service this product yourself as opening or removing covers may expose you to dangerous voltage or other hazards. Refer all servicing to qualified service personnel.

WARNING : Handling the cord on this product or cords associated with accessories sold with this product, will expose you to lead, a chemical known to the State of California to cause birth defects or other reproductive harm.
Wash hands after handling.

■ **Damage Requiring Service** – Unplug this product from the wall outlet and refer servicing to qualified service personnel under the following conditions:

- When the power-supply cord or plug is damaged.
- If liquid has been spilled, or objects have fallen into the product.
- If the product has been exposed to rain or water.
- If the product does not operate normally by following the operating instructions. Adjust only those controls that are covered by the operating instructions as an improper adjustment of other controls may result in damage and will often require extensive work by a qualified technician to restore the product to its normal operation.
- If the product has been dropped or damaged in any way.
- When the product exhibits a distinct change in performance - this indicates a need for service.

■ **Replacement Parts** – When replacement parts are required, be sure the service technician has used replacement parts specified by the manufacturer or have the same characteristics as the original part. Unauthorized substitutions may result in fire, electric shock or other hazards.

■ **Safety Check** – Upon completion of any service or repairs to this product, ask the service technician to perform safety checks to determine that the product is in proper operating condition.

■ **Heat** – The product should be situated away from heat sources such as radiators, heat registers, stoves, or other products (including amplifiers) that produce heat.

■ **Wall or Ceiling Mounting** - The product should be mounted to a wall or ceiling only as recommended by the manufacturer.

■ When the lamp is ON, don't touch the lamp or lamp cover. Negligence could result in burned injury.

■ Don't use this outdoors. Negligence could result in electric shock or fire.

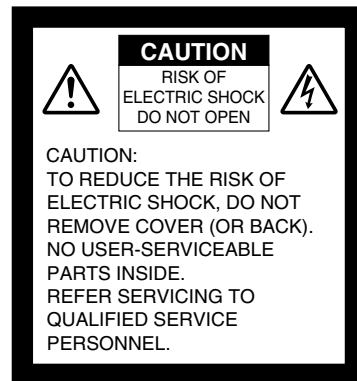



SA 1965

The lightning flash with arrowhead symbol, within an equilateral triangle, is intended to alert the user to the presence of uninsulated "dangerous voltage" within the product's enclosure that may be of sufficient magnitude to constitute a risk of electric shock to persons. This marking is located at the bottom of product.



SA 1966

The exclamation point within an equilateral triangle is intended to alert the user to the presence of important operating and maintenance (servicing) instructions in the literature accompanying the product.

**WARNING:
TO REDUCE THE RISK
OF FIRE OR ELECTRIC
SHOCK, DO NOT
EXPOSE THIS
PRODUCT TO RAIN OR
MOISTURE.**

**THIS IS A CLASS A
PRODUCT.
IN A DOMESTIC
ENVIRONMENT THIS
PRODUCT MAY CAUSE
RADIO
INTERFERENCE IN
WHICH CASE THE
USER MAY BE
REQUIRED TO TAKE
ADEQUATE MEASURES.**

INFORMATION

This equipment has been tested and found to comply with the limits for a Class A digital device, pursuant to Part 15 of the FCC Rules. These limits are designed to provide reasonable protection against harmful interference when the equipment is operated in a commercial environment. This equipment generates, uses, and can radiate radio frequency energy and, if not installed and used in accordance with the instruction manual, may cause harmful interference to radio communications. Operation of this equipment in a residential area is likely to cause harmful interference in which case the user will be required to correct the interference at his own expense.

USER-INSTALLER CAUTION:

Your authority to operate this FCC verified equipment could be voided if you make changes or modifications not expressly approved by the party responsible for compliance to Part 15 of the FCC rules.



BEFORE YOU USE

- Use this product under the rated electrical conditions.
- Do not leave this product under direct sunlight or by heaters, or this product may be discolored, deformed, or damaged.
- Do not place this product in any humid, dusty, windy or vibrating location. Use this product in the following environmental conditions:
 - Temperature: 5°C~40°C (41°F~104°F)
 - Humidity: 30%~85% (No condensation)
- Use a soft, dry cloth for cleaning. Do not use any volatile solvent, such as thinner or benzine.
- Do not directly point the camera lens into the sun, or the camera may be damaged.
- Although this product is equipped with a lamp, it is not a lighting system.
Do not use this product primarily as a lighting unit. Such use may cause fire or accident.
- Caring for the batteries:
 - If this product is not used for a long time, take out the batteries from the wireless remote control.
 - Do not use rechargeable Ni-Cd batteries.
 - Do not use new and old batteries, or batteries of different types together.
 - Do not try to recharge or short-circuit the batteries.

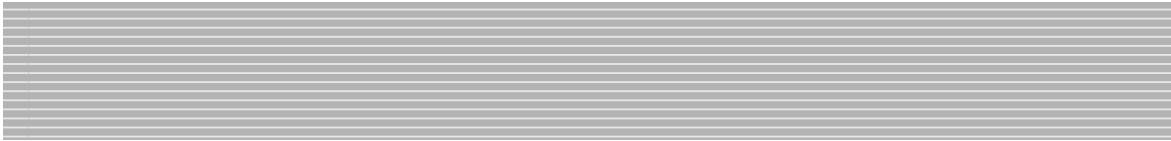

CONTENTS

1. PART NAMES AND FUNCTIONS

Appearance	8
Connector Panel	9
Wireless Remote Control	10

2. WIRELESS REMOTE CONTROL

Receivable Range	12
Preparation	12

3. MOUSE

Mouse Operation	13
-----------------------	----

4. INSTALLATION

Installation of the Unit	14
Setting of Auto Focus Operating Range	14
Connection to Monitor and Projector	15
Connection to the analog RGB-out terminal	15
Connection to the composite video-out terminal	15
Connection to the S video-out terminal	15

5. OPERATION PROCEDURES

Simple Steps for Presenting Printed Material	16
--	----

6. VARIOUS FUNCTIONS AND OPERATION

Lighting	17
Zoom	17
Digital Magnification	18
Color / B&W Selection	19
Posi / Nega Conversion	20
Image Rotation	20
Pause	21
Contrast	21
F.A.M. (Frame Accumulate Mode)	22
Iris	22
Auto iris adjustment	22
Focus	23
Auto Focus	23
Powered Manual Focus	24
Preset Operation	25
Image Memory	26
"Utility Software CD-ROM"	26

7. OSD (On-Screen Display)

OSD Operation	27
Main Menu	28
Sub Menu	30

1. PART NAMES AND FUNCTIONS▶ 1

2. WIRELESS REMOTE CONTROL▶ 2

3. MOUSE▶ 3

4. INSTALLATION▶ 4

5. OPERATION PROCEDURES▶ 5

6. VARIOUS FUNCTION AND OPERATIONS▶ 6

7. OSD▶ 7

8. RS-232C SPECIFICATIONS▶ 8

9. REPLACING THE LAMP▶ 9

10. TROUBLESHOOTING HINTS▶ 10

11. SPECIFICATIONS▶ 11

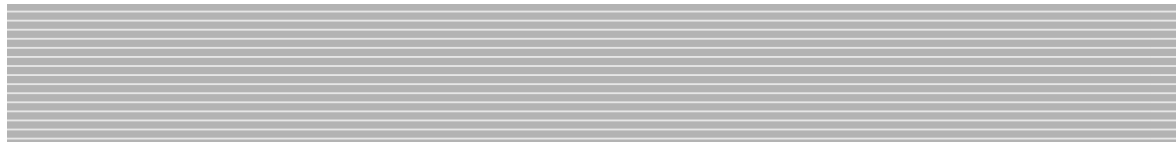

1	1. PART NAMES AND FUNCTIONS
2	2. WIRELESS REMOTE CONTROL
3	3. MOUSE
4	4. INSTALLATION
5	5. OPERATION PROCEDURES
6	6. VARIOUS FUNCTION AND OPERATIONS
7	7. OSD
8	8. RS-232C SPECIFICATIONS
9	9. REPLACING THE LAMP
10	10. TROUBLESHOOTING HINTS
11	11. SPECIFICATIONS

CONTENTS

8. RS-232C SPECIFICATIONS

Setting Up.....	32
Cable Connection.....	32
Connection	33
Transmission Specifications	33
Data Format Specifications.....	33
Transmission command (PC → Ceiling Presenter)	33
Response data format (Ceiling Presenter → PC).....	34
UART Communication Format.....	35

9. REPLACING THE LAMP

Replacing the Lamp	37
--------------------------	----

10. TROUBLESHOOTING HINTS

Symptoms and Confirmation	38
---------------------------------	----

11. SPECIFICATIONS

General.....	39
Camera.....	40
Lighting	40
Supplied Accessories.....	41
Optional parts (to be purchased separately)	41

1 PART NAMES AND FUNCTIONS

Appearance

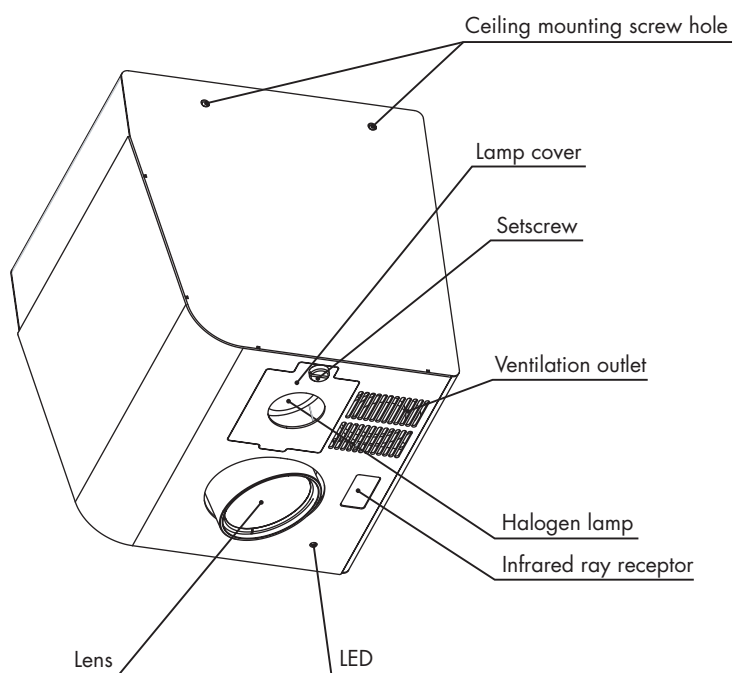

1

2

3

4

5

6

7

8

9

10

11

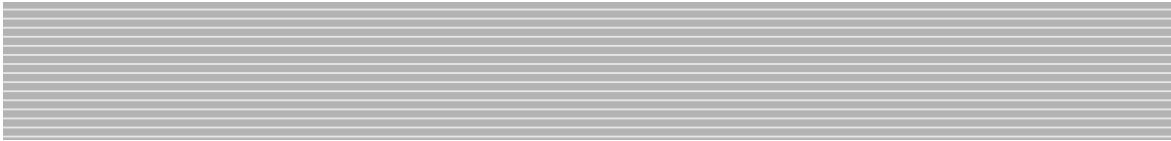

- 1
- 2
- 3
- 4
- 5
- 6
- 7
- 8
- 9
- 10
- 11

Connector Panel

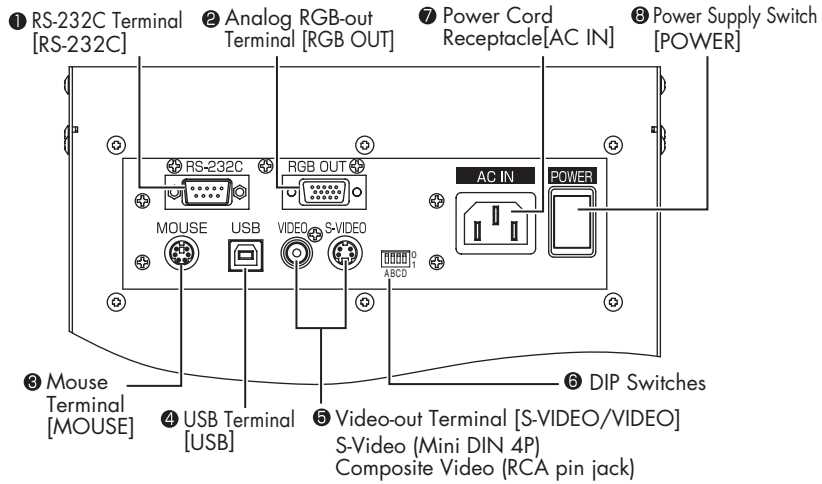

	Name	Function	Reference Page															
1	RS-232C Terminal [RS-232C]	To connect the RS-232C cable when controlling the unit from the PC.	P.32															
2	Analog RGB-out Terminal [RGB OUT]	Image is output when this terminal is connected to RGB input equipment (e.g., LCD projector, multi-sync monitor).	P.15															
3	Mouse Terminal [MOUSE]	To connect the mouse (supplied accessory)(* 1).	P.13															
4	USB Terminal [USB]	If connected to personal computer with the attached USB cable, it is possible to transfer images and control the unit by using the software in the attached Utility Software CD-ROM.(* 1)	P.26															
5	Video-out Terminal [S-VIDEO/VIDEO] S-Video (Mini DIN 4P) Composite Video (RCA pin jack)	To output images to the NTSC/PAL monitor, such as TV monitor.	P.15															
6	DIP Switches	<p>The functions can be changed as follows:</p> <ul style="list-style-type: none"> ◇[A] key: To change the video output type. ◇[B] key: To change the screen size of video output. ◇[C] key: Selects the operating range of AF. ◇[D] key: Selects the operating range of AF. <p>Key alignment and functions:</p> <table border="1" style="margin-left: 20px;"> <thead> <tr> <th></th> <th>[A] key</th> <th>[B] key</th> <th>[C] key</th> <th>[D] key</th> </tr> </thead> <tbody> <tr> <td>0</td> <td>NTSC</td> <td>Over scan</td> <td colspan="2">AF range selected</td> </tr> <tr> <td>1</td> <td>PAL</td> <td>Under scan</td> <td colspan="2">(See P. 14.)</td> </tr> </tbody> </table> <p> Before changing the DIP Switch keys, be sure to turn OFF the power supply to this product.</p>		[A] key	[B] key	[C] key	[D] key	0	NTSC	Over scan	AF range selected		1	PAL	Under scan	(See P. 14.)		P.14 P.15
	[A] key	[B] key	[C] key	[D] key														
0	NTSC	Over scan	AF range selected															
1	PAL	Under scan	(See P. 14.)															

(*1) For cable extension, use a cable specified for extension that is commercially available.

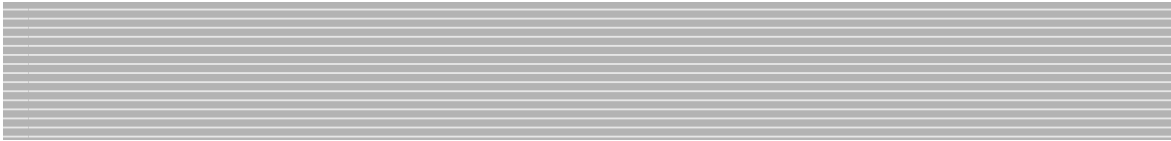

	Name	Function	Reference Page
7	Power Cord Receptacle [AC IN]	Connected to the power cord connector.	
8	Power Supply Switch [POWER]	To turn ON/OFF the power supply.	

Wireless Remote Control

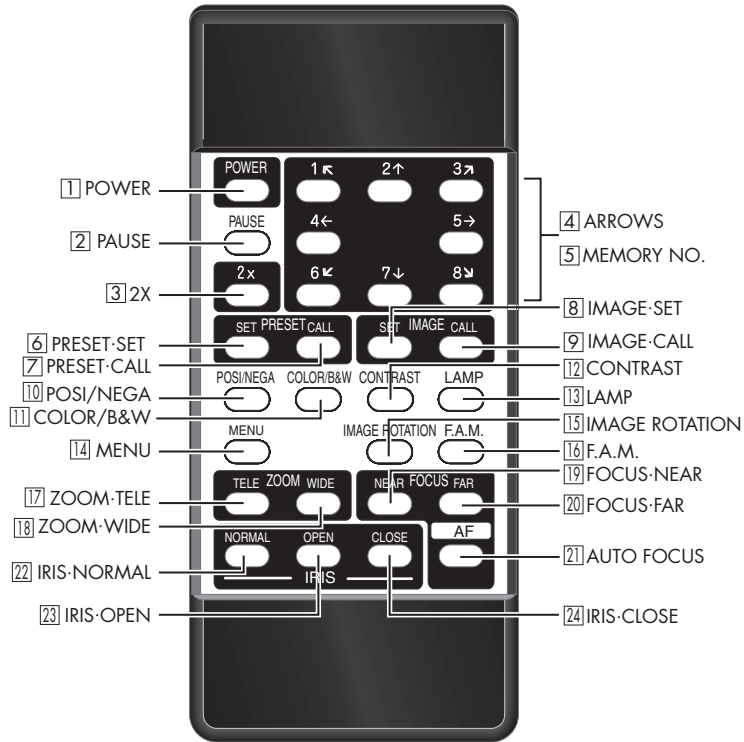

- 1
- 2
- 3
- 4
- 5
- 6
- 7
- 8
- 9
- 10
- 11

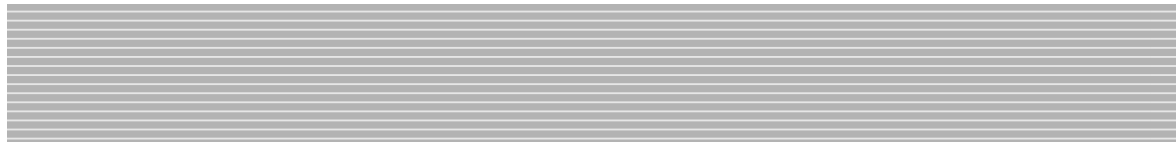

- 1
- 2
- 3
- 4
- 5
- 6
- 7
- 8
- 9
- 10
- 11

	Button Name		Function	Reference Page
[1]	POWER		To turn ON/OFF the power supply.	P.16
[2]	PAUSE		To switch pause/motion of the image.	P.21
[3]	DIGITAL MAGNIFICATION	2X	To double the image size.	P.18
[4]		ARROWS	To scroll the magnified screen. This can also be used to move the pointer when the pointer is displayed.	
[5]	MEMORY NO.		The memory No. Used with [6] to [9].	
[6]	STATUS	PRESET-SET	To store the operating condition of the unit. Used with the MEMORY NO.	P.25
[7]		PRESET-CALL	To call the stored operating condition. Used with the MEMORY NO.	
[8]	IMAGE	IMAGE-SET	To store images in the unit's memory. Used with the MEMORY NO.	P.26
[9]		IMAGE-CALL	To call the image stored by [IMAGE-SET] button. Used with the MEMORY NO.	
[10]	POSI/NEGA		To change POSI/NEGA.	P.20
[11]	COLOR/B&W		To change COLOR/B&W.	P.19
[12]	CONTRAST		To turn ON/OFF the contrast enhancement.	P.21
[13]	LAMP		To turn ON/OFF the lamp.	P.17
[14]	MENU		To turn ON/OFF the pointer and the OSD menu. Determine the OSD menu pointed by the pointer.	P.27
[15]	IMAGE ROTATION		To rotate the image anticlockwise by 90°.	P.20
[16]	F.A.M.		To reduce the rough noise of the image.	P.22
[17]	ZOOM	TELE	To zoom in.	P.17
[18]		WIDE	To zoom out.	
[19]	FOCUS	NEAR	To move the focus near.	P.24
[20]		FAR	To move the focus far.	
[21]		AUTO FOCUS	To focus automatically.	P.23
[22]	IRIS	NORMAL	To reset the AUTO IRIS to the initial value.	P.22
[23]		OPEN	To open the AUTO/MANUAL IRIS.	
[24]		CLOSE	To close the AUTO/MANUAL IRIS.	

2 WIRELESS REMOTE CONTROL

Receivable Range

 Point the infrared emitting part of the wireless remote control at the infrared sensor of this product, and press the button for desired function. The receivable range may be narrowed or the light may not be received when this product is placed under sunlight, near an inverter fluorescent lamp or in any other unfavorable surroundings. Take measures such as shielding the sunlight and the light from inverter fluorescent lamp.

- Receivable range

Distance : Approx. 7 m (23 ft.) or less from the light receiving area to the front of the wireless remote control.

Angle : Approx. 30° degrees or less from the light receiving area upward and downward, approx. 50°degrees or less from the light receiving area rightward and leftward.

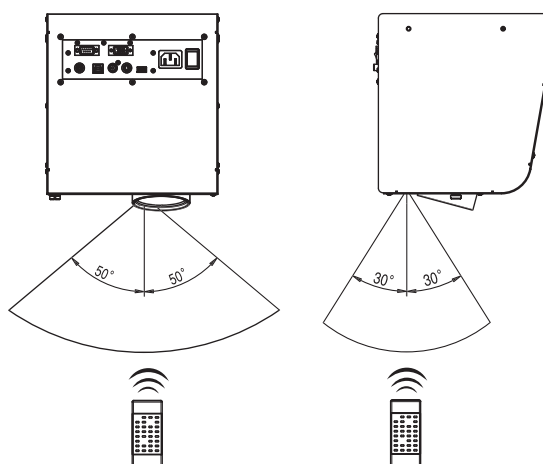

Preparation

Remove the battery case cover by pressing downward on the [↓OPEN] mark part in the direction as indicated by the arrow.

Install 2 pcs. of batteries (type R03, AAA) into the case in the direction as indicated there.

 Install the batteries according to polarity.

 Change the batteries once a year.

 The batteries supplied with this product are only for use in initially confirming the operation of this product. It is not guaranteed that these batteries can work effectively for the indicated period.

1

2

3

4

5

6

7

8

9

10

11

3 MOUSE

- 1
- 2
- 3
- 4
- 5
- 6
- 7
- 8
- 9
- 10
- 11

Mouse Operation

Connect the mouse to the mouse terminal [MOUSE] on the connector panel.

- Click the left button
To operate the OSD menu.
When digital magnification or image rotation (90°, 270°) is not used, the pointer and OSD menu can be displayed/deleted.
- Drag by left button (moves while button is being pushed)
In time of digital magnification or image rotation (90°, 270°), screen is scrolled.
- Click the mouse wheel
To display or clear the pointer and OSD menu alternately by clicking.

Mouse

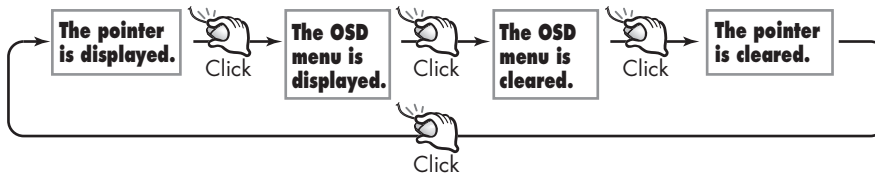
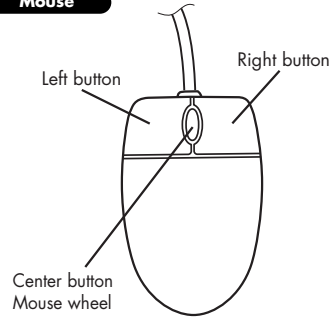

- Roll the mouse wheel
To scroll the screen up/down when the image is in digital magnification or rotated to 90° or 270°.
- Click the right button
When this button is clicked for digital magnification while the pointer is displayed, the position of the pointer is the center of the magnified image.
When the pointer is not displayed, the center position of the image is digitally magnified.

- Click the OSD menu, then the menu functions are given priority.
- When using the mouse, connect the mouse before turning ON the power supply to this product.
- Use the attached mouse. If another mouse is used, the normal operation cannot be guaranteed. If the cable is extended, use the commercial cable for extension or consult the distributor.
- The OSD menu is assumed to be used for large projection sizes with a projector or the like. Therefore, the display on a hand monitor or a TV may be hard to see.

Reference Page

- Digital Magnification **P.18**
- OSD **P.27**

4 INSTALLATION

Installation of the Unit

For the ceiling mounting metal piece, VB-1000 separately available, any product approved by UL Standard for projector which is capable of supporting a load of 8-10 kg or more, or similar product also approved by UL Standard shall be used. Request your distributor to install this product on the ceiling. For details, refer to the HV-C1000XG Installation Manual included in the package.

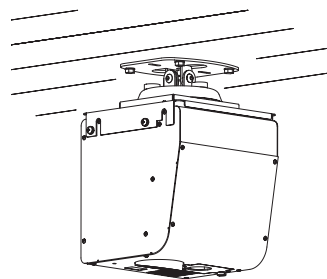

Connect the power supply cord with the Power Cord Receptacle of this product and plug outlet. Turn ON the Power Supply Switch.



When this product is not used for a long time, turn OFF the Power Supply Switch or remove the power supply plug from the outlet.



Provide a distance of 1.3m or more between the unit and the document to be projected. Images can be focused when the distance increases; however, the light intensity may be insufficient. If the distance is more than 3m, external lighting is needed.

Setting of Auto Focus Operating Range

The following settings of this product can be changed with the DIP Switches. Change the settings according to the connection environment. The factory settings are as shown in the following table:

AF operating range (Shooting distance)	[C] key	[D] key
Whole area (1.3m~∞)	0	0
1.3m ~ 1.8m	1	0
1.7m ~ 2.8m	0	1
2.7m ~ ∞	1	1



In delivery from plant, the whole area is set.



When changing the DIP Switch keys, be sure to turn OFF the power supply to this product beforehand.

1

2

3

4

5

6

7

8

9

10

11

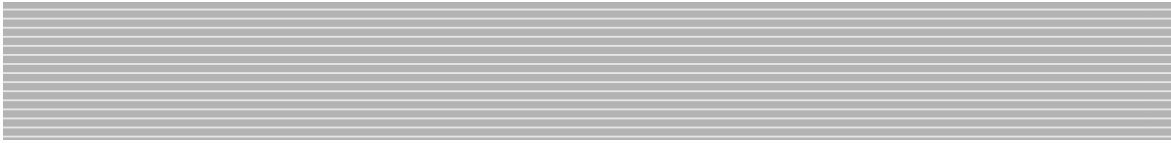

- 1
- 2
- 3
- 4
- 5
- 6
- 7
- 8
- 9
- 10
- 11

Connection to Monitor and Projector

The following settings of this product can be made with the DIP Switches. Make the settings according to the connection environment. The factory settings are as shown in the following table:

Key	Function	Initial setting	
		Key selection	Content
A	To change the Video output type	1	NTSC
B	To change the screen size of Video output	0	Over scan

- Be sure to turn OFF the power supply to all equipment before making any connections to protect this product and all the connected equipment.
- When changing the DIP Switch keys, be sure to turn OFF the power supply to this product beforehand.

■ Connection to the analog RGB-out terminal

Connect the Analog RGB-out Terminal [RGB OUT] to the equipment with an analog RGB-in terminal with the analog RGB cable (attached) or a connection cable available on the market. At this time, the position of the display may be deviated from the center. If deviated, manually adjust the horizontal and vertical positions on the connected equipment. Also, vertical stripes may appear on the screen of the LCD projector. That can be alleviated by manually adjusting the dot clock frequency on the projector.

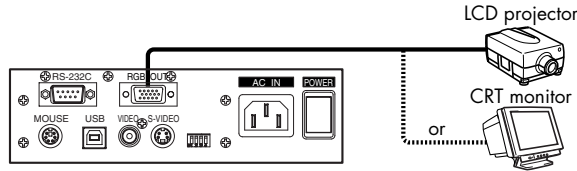

■ Connection to the composite video-out terminal

Use the Composite Video-out Terminal [VIDEO](RCA pin) and the video cable with RCA pin plug as attached or available on the market.

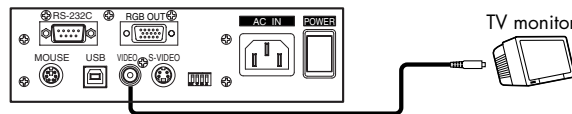

■ Connection to the S video-out terminal

Use the S Video-out Terminal [S-VIDEO](Mini DIN 4P) and the S-Video cable as attached or available on the market.

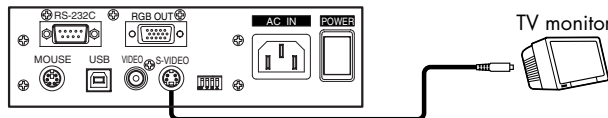

- Hold the cable plug when connecting or disconnecting the cables.

5 OPERATION PROCEDURES

Simple Steps for Presenting Printed Material

- (1) Push the **[POWER]** button of the wireless remote control to turn ON the power (Indicator LED on the unit turns from red to green).



Connection with the monitor should be done in advance.



If the Power Supply Switch is turned ON immediately after it is turned OFF, this product may not operate.
To restart operation, turn ON the Power Supply Switch after several seconds.



When the document surface is dark, turn ON the lamp by pressing the **[LAMP]** button.



After the power supply is turned ON, it takes about 10 seconds to execute the initialization of the unit and output the image.

- (2) Place an object on the document surface and adjust the image size using **[ZOOM-TELE]** and **[ZOOM-WIDE]** buttons on the wireless remote control as you watch the monitor screen so that the projected image may be in compliance with the object.

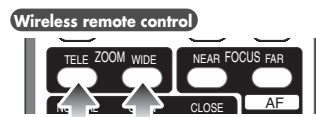

- (3) Adjust the focus by pressing the **[FOCUS-N/F]** (**NEAR/FAR**) buttons of the wireless remote control. The focus can be also adjusted by pressing the **[AF]** (**AUTO FOCUS**) button.

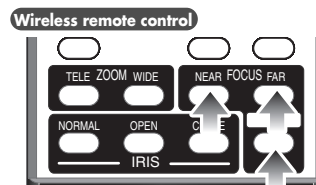

- (4) After finishing the operation, turn OFF the **[POWER]** button of the wireless remote control. (Indicator LED on the unit turns from green to red.)

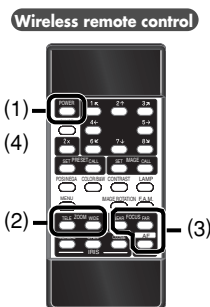

1

2

3

4

5

6

7

8

9

10

11

6 VARIOUS FUNCTIONS AND OPERATION

1

Lighting

2

Lighting for presenting information such as printed materials is provided.

When the **[LAMP]** button on the wireless remote control is pressed, the lamp is lit.

3

When the **[LAMP]** button is pressed again, the lamp goes off.

4



To obtain a sharp image with good color rendering, it is sometimes necessary to use the lighting.

5



When the lighting provided by the unit is insufficient, use external lighting.

6

Wireless remote control

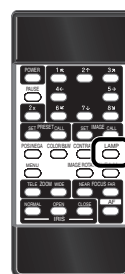

Wireless remote control



7

Zoom

8

Press the **[ZOOM-TELE]** button on the wireless remote control, and the image will gradually be magnified.

9

Press the **[ZOOM-WIDE]** button on the wireless remote control, and the image will gradually be reduced.

10

Also, by continuously pressing the ZOOM button, the zooming speed becomes faster. (Double speed function)

11

Wireless remote control

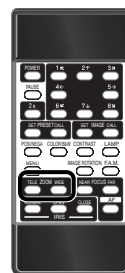

Wireless remote control

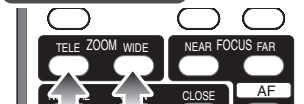

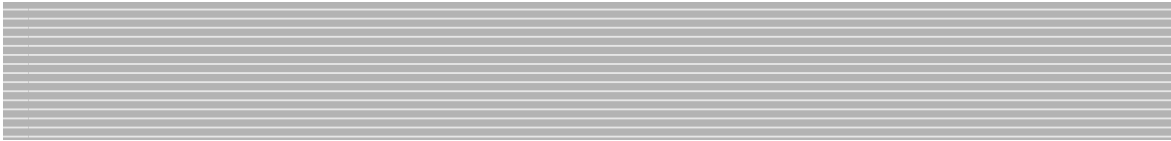

Digital Magnification

To double the image, press the **[2x]** button on the wireless remote control or click the Right button of the mouse.

Enlarged screen can be scrolled by operating the arrow button on the wireless remote control or by operating the mouse.



If the OSD menu is displayed on the digitally magnified screen, the magnified screen cannot be scrolled by the wireless remote control.

• The mouse can be operated as follows:



- Left button..... To scroll the image according to the dragging of the mouse while holding down the left button.
- Mouse wheel To scroll up/down the magnified screen.
- Right button To turn ON/OFF the double enlargement. When any image is magnified digitally, the pointer becomes the mark X.



When the digital magnification is tried while the mouse pointer is in display, since the left button of the mouse is limited to the scroll function, the mouse pointer and the OSD menu cannot be turned ON/OFF.

To turn ON/OFF the mouse pointer and the OSD menu, turn OFF the digital magnification.

Wireless remote control

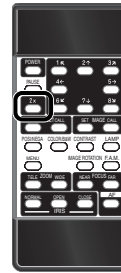

Wireless remote control

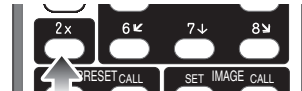

Reference Page

- Mouse **P.13**
- OSD **P.27**

1

2

3

4

5

6

7

8

9

10

11

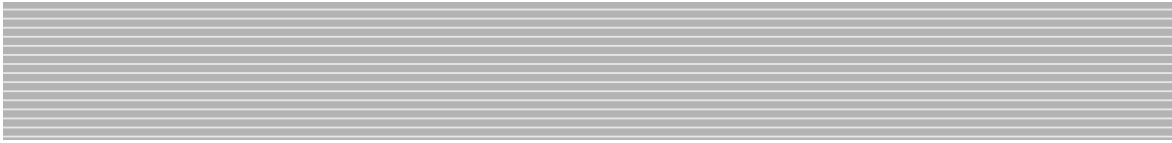

- 1
- 2
- 3
- 4
- 5
- 6**
- 7
- 8
- 9
- 10
- 11

Color / B&W Selection

To present the B&W (Black&White) material such as documents. Sharper image with no color blur on the monitor can be produced.

If the **[COLOR/B&W]** button on the wireless remote control is pressed, images are switched.



When PAUSE is effective, COLOR/B&W selection does not work.

Wireless remote control

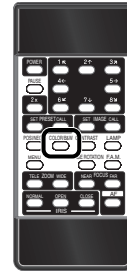

Wireless remote control



Reference Page

- OSD..... **P.27**

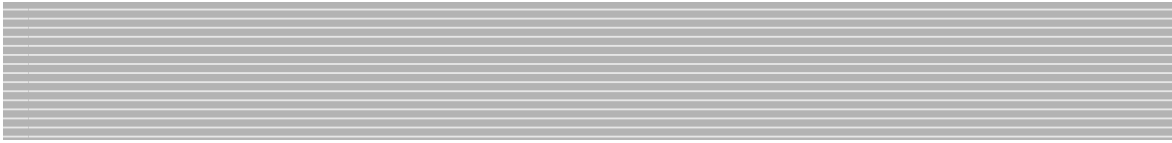

Posi / Nega Conversion

To show a negative film.

Press the **[POSI / NEGA]** button on the wireless remote control, the image will be converted to the NEGA mode accordingly.

When the **[POSI / NEGA]** button is pressed again, the POSI mode is resumed.



When using the NEGA conversion mode, use of the following is restricted.

- With CONTRAST ON: Gamma adjustment is not available.
- Only with Gamma setting $\gamma = 0.7$: CONTRAST can be turned ON.



NEGA setting at the factory

- Gamma: $\gamma = 0.7$ (0.3)
- CONTRAST: ON



When PAUSE is effective, POSI/NEGA conversion does not work.

Wireless remote control

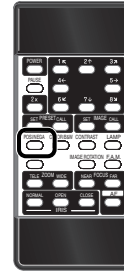

Wireless remote control



Reference Page

- OSD..... **P.27**

1

2

3

4

5

6

Image Rotation

When the **[IMAGE ROTATION]** button on the wireless remote control is pressed, the image rotates.

Every time the **[IMAGE ROTATION]** button is pressed, the image rotates counterclockwise by 90°.



The image does not rotate when PAUSE mode is working.

Wireless remote control

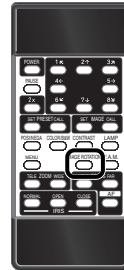

Wireless remote control



Reference Page

- OSD..... **P.27**

7

8

9

10

11

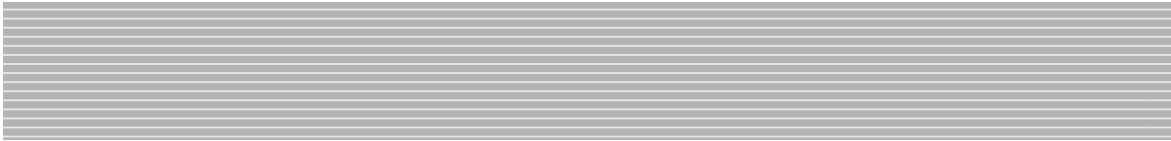

- 1
- 2
- 3
- 4
- 5
- 6

Pause

When the **[PAUSE]** button on the wireless remote control is pressed, the image from the unit's camera pauses. When the **[PAUSE]** button is pressed again, the PAUSE mode is canceled.

 When PAUSE is effective, POSI/NEGA conversion, IMAGE ROTATION, COLOR/B&W selection, F.A.M., and CONTRAST functions do not work.

 Although the ZOOM, FOCUS, and IRIS functions are effective, the results are not reflected in the image in this mode.

Wireless remote control

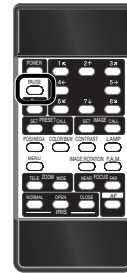

Wireless remote control

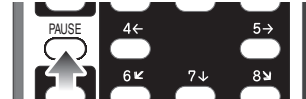

Reference Page

• OSD..... **P.27**

- 7
- 8
- 9
- 10
- 11

Contrast

To present the material with a little half tone such as texts.

Images with sharp characters and lines contrasty with background can be obtained.

When the **[CONTRAST]** button on the wireless remote control is pressed, the image becomes contrasty.

When the **[CONTRAST]** button is pressed again, the image is reset to the normal condition.

 When using NEGA conversion, the CONTRAST can only be turned ON if Gamma setting is $\gamma = 0.7$ (0.3).

 CONTRAST does not function while PAUSE is functioning.

Wireless remote control

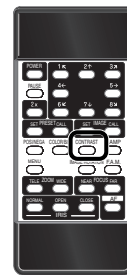

Wireless remote control



Reference Page

• OSD..... **P.27**

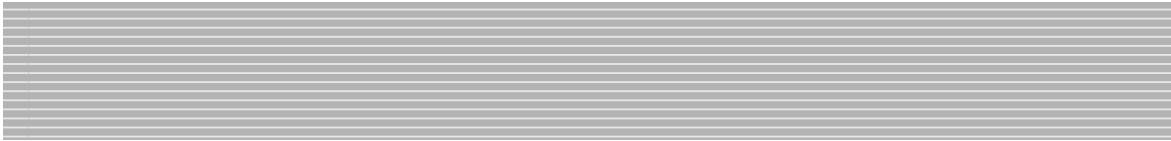

F.A.M. (Frame Accumulate Mode)

This is used to reduce artifacts of the image, and is appropriate to take pictures of still objects. Press the **[F.A.M.]** (Frame Accumulate Mode) button on the wireless remote control, and the **[F.A.M.]** is selected. Press the **[F.A.M.]** (Frame Accumulate Mode) button again, and the normal status is resumed.



[F.A.M.] does not function while the image is rotated or PAUSE is functioning.

Wireless remote control



Wireless remote control

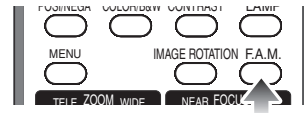

1

2

3

4

5

6

Iris

■ Auto iris adjustment

By adjusting the diaphragm, the brightness will automatically follow changes of brightness according to the object.

Press the **[IRIS-OPEN]** button on the wireless remote control to open the iris.

Press the **[IRIS-CLOSE]** button on the wireless remote control to close the iris.

Press the **[IRIS-NORMAL]** button on the wireless remote control, to change setting back to the defaults.



Use RS-232C interface for MANUAL IRIS operation.

Wireless remote control

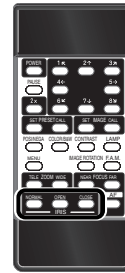

Wireless remote control

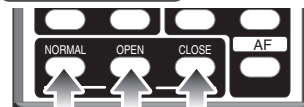

7

8

9

10

11

Reference Page

- OSD..... P.27

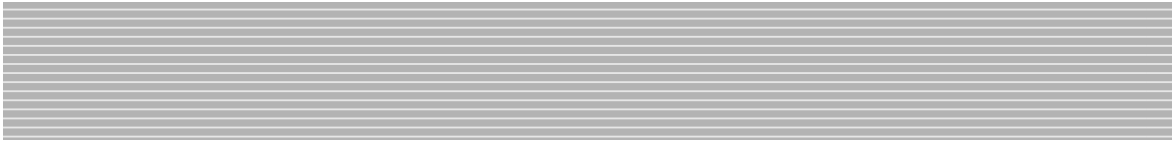

- 1
- 2
- 3
- 4
- 5
- 6
- 7
- 8
- 9
- 10
- 11

Focus

Adjust the focus of the object.

■ Auto Focus

When the **[AF](AUTO FOCUS)** button on the wireless remote control is pressed, the focus is set automatically.

This product features a one-push AUTO FOCUS function. Once focusing is completed, the AUTO FOCUS function is released, and the focused position maintains unchanged (FOCUSFREE).

 The objects listed below may not be brought into focus in the AUTO FOCUS mode. In these cases, use the MANUAL FOCUS mode.

- Objects bearing little contrast
- Objects with fine repeated patterns, such as lateral stripes and cross stripes
- Objects glittering or reflecting strong light
- Objects with bright background, or excessive contrast
- The whole image is dark.
- Objects located near and far away at the same time
- Objects in motion

 Some objects require a long auto focus time.

 When the MANUAL FOCUS buttons (**[FOCUS-NEAR]** or **[FOCUS-FAR]** button) on the wireless remote control are pressed, the AUTO FOCUS operation is reset.

 When the ZOOM buttons (**[ZOOM-TELE]** or **[ZOOM-WIDE]** buttons) on the wireless remote control are pressed, the AUTO FOCUS operation is suspended.

 If some other operation is performed in AUTO FOCUS operation, the AUTO FOCUS operation may not be completed normally.

 FOCUS can be adjusted at a distance of 1.3m or more from the unit to the object in the max. side of **[ZOOM-TELE]**.

Wireless remote control

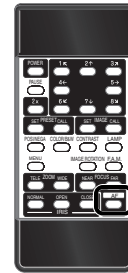

Wireless remote control

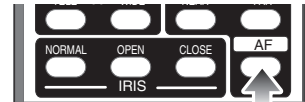

Reference Page

- OSD..... **P.27**

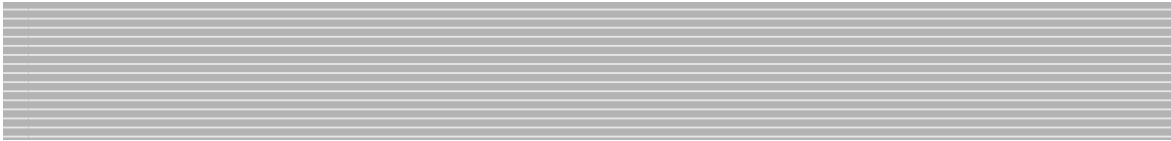

■ Power Manual Focus

To focus on specific part of the material, such as 3-D material. Press the FOCUS button [**FOCUS-NEAR**] or [**FOCUS-FAR**] on the wireless remote control.



This product can finely adjust the focus. For minor adjustments, press the FOCUS button several times. For major adjustments, keep the FOCUS button pressed, then the focus begins to move more quickly.



Focus can be adjusted at a distance of 1.3 m or more from the unit to the object in the max. side of [**ZOOM-TELE**].

Wireless remote control

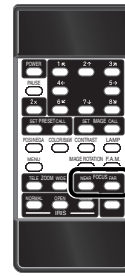

1

2

3

Wireless remote control



4

5

Reference Page

- OSD..... P.27

6

7

8

9

10

11

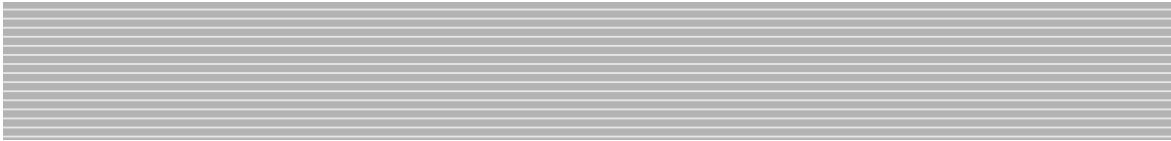

- 1
- 2
- 3
- 4
- 5
- 6
- 7
- 8
- 9
- 10
- 11

Preset Operation

Operation status of this product can be stored / read out in the memory (max. 8 states can be stored). Operation states that can be stored are as shown below.

- Present zoom angle of view
- Status of IRIS
- White Balance status
- ON/OFF of Aperture
- Status of Gamma
- Lighting status
- Status of COLOR/B&W switch
- Condition including pointer ON/OFF, color and shape
- Condition of IMAGE ROTATION
- ON/OFF of CONTRAST mode
- Status of POSI/NEGA conversion
- Status of F.A.M. selection

1. How to store

Press the **[PRESET•SET]** button on the wireless remote control and press the MEMORY NO. button of the wireless remote control within 4 sec then the current status of this product is saved in the pressed number memory.

The preset (stored) status is maintained even when the power is turned OFF.

2. How to read out operation status

Press the **[PRESET•CALL]** button on the wireless remote control and press the MEMORY NO. button of the wireless remote control within 4 sec then this product is set to the memorized status corresponding to the number.

Wireless remote control

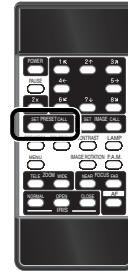

Wireless remote control

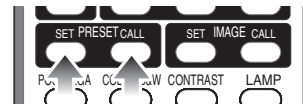

Reference Page

- OSD..... **P.27**

Image Memory

Images can be stored / called in the memory of this product (max. 8 images).

1. Press the **[IMAGE-SET]** button on the wireless remote control and press the MEMORY NO. button of the wireless remote control within 4 sec then the image is stored in the pressed number.



When the Power Supply is turned OFF by pressing the **[POWER]** button of the wireless remote control, the images stored in the memory are deleted.

2. How to read out stored images

Press the **[IMAGE-CALL]** button on the wireless remote control and press the MEMORY NO. button of the wireless remote control within 4 sec then the image in the memory corresponding to the pressed number is read out.



To return to the normal camera image, press the **[IMAGE-CALL]** button again "within 4 seconds".



The image cannot be saved in the number from which the image is read.

Wireless remote control

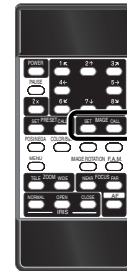

Wireless remote control



Reference Page

• OSD..... P.27

"Utility Software CD-ROM"

The attached "Utility Software CD-ROM" contains the PC link software "Image Mate" and the TWAIN driver "ELMO TWAIN DS," and can be operated as shown below.

- To transfer graphic data to PC.
- To operate this product by PC.

For details, see the Installation Manual for "Utility Software" and "manual.pdf" in the CD-ROM.

1

2

3

4

5

6

7

8

9

10

11

7 OSD (On-Screen Display)

1

OSD (On-Screen Display) means the operating menu displayed on the screen (hereinafter called OSD menu).

2

The OSD menu is operable by the wireless remote control or mouse.

OSD Operation

3

1. When the **[MENU]** button on the wireless remote control is pressed, a pointer is displayed.

4

2. If the **[MENU]** button is pushed again, the OSD menu is displayed, and the pointer moves to the lower left area of the OSD menu.

5

3. Move the pointer to the required icon. The pointer can be moved by pushing the ARROW buttons. (Same as MEMORY NO. buttons for image memory/PRESET operation.)

6

4. When the **[MENU]** button is pressed, the icon is pressed and the corresponding operation is executed.

7

5. To end the OSD menu, keep pushing the up/down ARROW button to move the pointer out of the OSD area. Then push the **[MENU]** button, and the OSD menu goes off. If the **[MENU]** button is pushed again, the pointer goes off.

8



While the OSD menu is on the display, the pointer of the wireless remote control moves only on the icons in the OSD menu. (Color of icons is turned red).

If the sub-menu is displayed, the pointer moves only on the functional items. To move to another icon, close the sub-menu, and move the pointer.

9



When a pointer form is changed on the OSD menu, this setting is subsequently used.

10

11

Wireless remote control

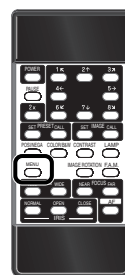

Wireless remote control



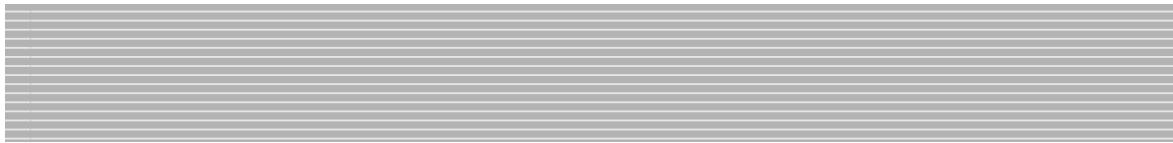



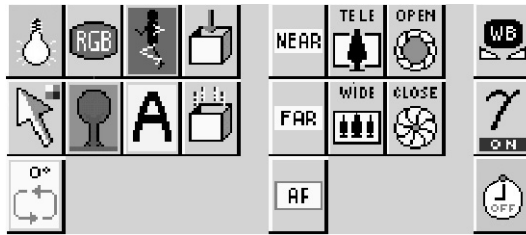





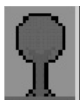



Main Menu

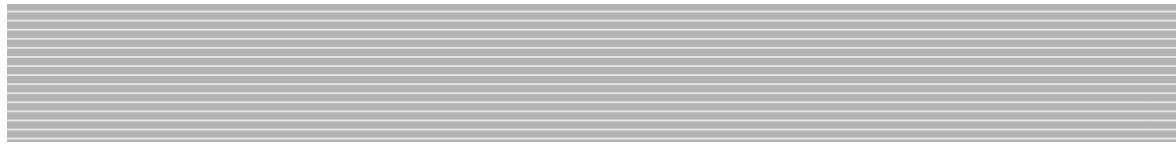

- 1
- 2
- 3
- 4
- 5
- 6
- 7
- 8
- 9
- 10
- 11

Icon	Name	Function	Reference Pages
	Lamp	To turn ON/OFF the lighting. When power is turned ON, the previous saved setting remains.	P.17
	Color/B&W selection	To switch the selection of the Color/B&W of the screen. When power is turned ON, the previous saved setting remains.	P.19
	Posi/Nega conversion	To switch the selection of the positive/negative of the screen. When power is turned ON, the previous saved setting remains.	P.20
	Image rotation	To rotate the image counterclockwise by 90°. When power is turned ON, the previous saved setting remains.	P.20
	Pause	To switch the selection of the static/moving image. When power is turned ON, the initial state is Animation.	P.21
	Aperture selection	To switch the modulation (edge emphasis) of the image. When power is turned ON, the previous saved setting remains.	
	Pointer	To change the color and shape of the pointer on the screen. Every time the left button of the mouse is clicked, the icon pointer is switched in order of "[White arrow → Blue arrow → Yellow arrow → Red arrow] → [White line → Blue line → Yellow line → Red line]".	

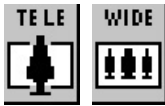
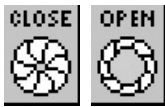

	Icon	Name	Function	Reference Pages
1		Status saving	To save initial status when power is turned ON. For the mouse pointer ON/OFF selection the same items stored in the Preset/Move operation are saved.	P.25
2				
3		Initialization	To reset this product to the status of the factory settings.	
4		Focus Near/Far	To adjust the focus .	P.24
5		Auto Focus	To focus automatically.	P.23
6				
7		Zoom Tele/Wide	To adjust the zoom of the lens.	P.17
8		Iris Close/Open	To adjust the iris of the lens.  Auto/Manual selection cannot be changed by the OSD.	P.22
9				
10				
11				

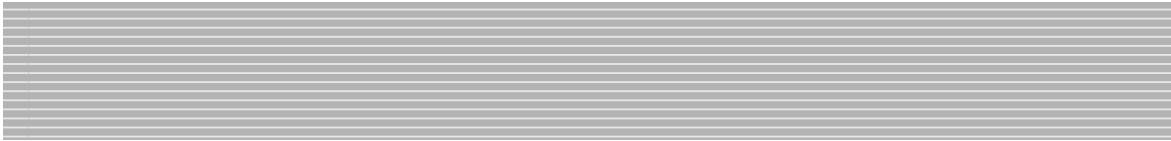

Sub Menu

○ **White Balance Adjustment menu**



○ **Gamma menu**



○ **Power Supply Off Timer**



Icon	Name	Function	Reference Page
	White Balance	To display the White Balance Adjustment menu. When this button is pressed again, the White Balance Adjustment menu is closed.	
	Auto	To set the White Balance in the AUTO FOLLOW mode. (initial setting)	
	One-push	To set the push-set White Balance. When this button is pressed the white balance for the then color temperature is fixed.	
	Manual	To set the white balance with <RED>, <GREEN> and <BLUE>. Adjust the white balance by pressing the mouse button on the direction buttons beside the volume bar. <RED>...To adjust the red component (01-99). <GREEN>...To adjust the green component (01-99). <BLUE>...To adjust the blue component (01-99).	

1

2

3

4

5

6

7

8



9

10

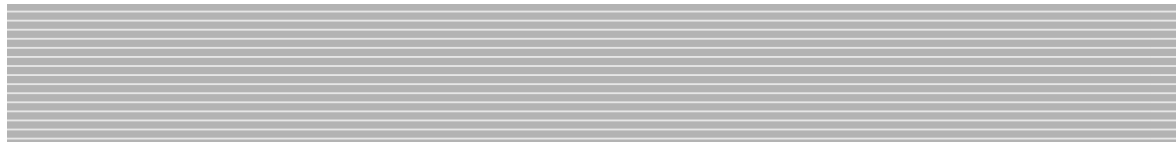
11



- 1
- 2
- 3
- 4
- 5
- 6
- 7
- 8
- 9
- 10
- 11

Icon	Name	Function	Reference Page
	Gamma adjustment (00~07)	To change the Gamma setting value (00(1.0) / 01(0.9) / 02(0.8) / 03(0.7) / 04(0.6) / 05(0.5) / 06(0.4) / 07(0.3)). The factory setting is "04 (0.6)." Gamma cannot be adjusted when the CONTRAST is ON in the negative status.	
	Power Supply Off Timer	Sets the time between end of operation and power OFF. The time can be set within the range from 01 (1h) to 08 (8h). When 00 is set, the timer does not operate. If Power Supply is turned OFF, the indicator LED turns orange.	

8 RS-232C SPECIFICATIONS

This product can be controlled by a PC connected through the RS-232C terminal [RS-232C].

Setting Up

(1) Connect this product to a PC with an RS-232C connection cable.



When using an RS-232C cable available in the market, select a cable with the connection shown below.



To protect this product and the PC, be sure to turn OFF all the power supply of all equipment before connecting.

(2) Start the PC, and set the communication mode of the RS-232C to the communication mode of this product.



For the information how to set the communication mode of the RS-232C, refer to the instruction manual of the PC.

(3) Start the PC program to operate this product.

(4) Control through the RS-232C will start.



For communication control, be sure to take the above steps for setting.

Cable Connection

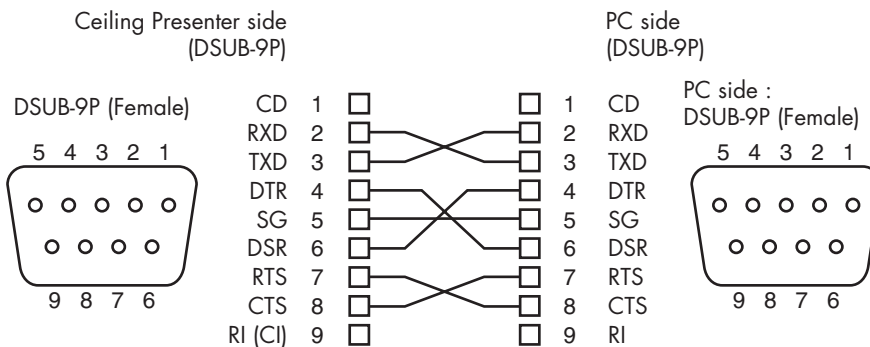

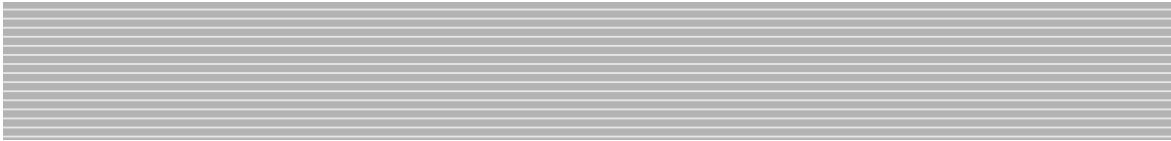

1

Connection

If the RS-232C cable is not correctly connected between this product and the PC, no acknowledgement is transmitted. Connect the RS-232C cable correctly, and fix it firmly with the connector set screws before the operation.

2

3

Transmission Specifications

- Full duplex start-stop sync. mode
- Start bit : 1 bit
- Data bit : 8 bits
- Stop bit : 1 bit
- Parity bit : None
- X parameter : None
- Baud rate (Communication speed) : 9600bps

4

5

6

Data Format Specifications

This command is executed in the form of 1-command/1 packet. The next command is not accepted until the previous processing is completed.

7

- The communication command always starts with STX (Start of Text) , and ends with ETX (End of Text) .
- If the communication format or command name is wrong, NAK (Negative Acknowledgement) will be sent from this product.
- When the communication format is correctly received, this product sends ACK (Normal Acknowledgement).

8

■ Transmission command (PC → Ceiling Presenter)

Each operation command is executed in ASCII code, and transmitted in a set of 7 bytes as follows:

9

10

(PC)	S	Command	Parameter	Data	E
	T				T
	X				X

11

(Ceiling Presenter) → ACK

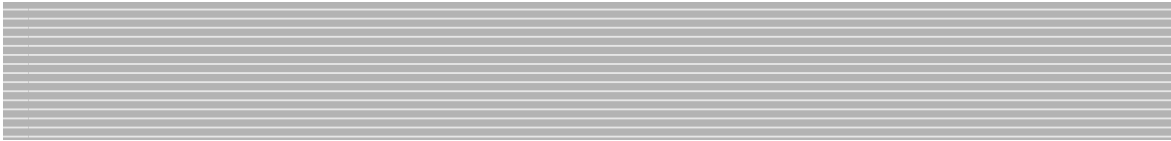

■ **Response data format (Ceiling Presenter→ PC)**

All response data is transmitted as ASCII code, and it covers parameter of the table of operation command table.

• Status 0

S T X	Lamp on/off	30H	Posi / Nega	Color / B&W	Pointer display	Digital Magnification	Pause	Local lockout	E T X
-------------	----------------	-----	----------------	----------------	--------------------	--------------------------	-------	------------------	-------------

• Status 2

S T X	32H	γ adjustment	Image rotation	Aperture	White Balance	Contrast	30H	30H (Normal) 31H (Adjustment)	E T X
-------------	-----	-----------------	-------------------	----------	------------------	----------	-----	--	-------------

• Status 7

S T X	F.A.M.	Iris mode	Power supply off time	20H	20H	20H	20H	20H	E T X
-------------	--------	--------------	-----------------------------	-----	-----	-----	-----	-----	-------------

AUTO:31H
MANUAL:32H

• Status 8

S T X	Image memory8	Image memory7	Image memory6	Image memory5	Image memory4	Image memory3	Image memory2	Image memory1	E T X
-------------	------------------	------------------	------------------	------------------	------------------	------------------	------------------	------------------	-------------

 Byte not storing images is 30H.
Byte storing images is 31H.
Byte reading out images is 32H.

• ROM version

S T X	V 56H	H 48H	K 4BH	20H	* * H	* * H	E T X
-------------	----------	----------	----------	-----	-------	-------	-------------

ROM version 1 ROM version 2



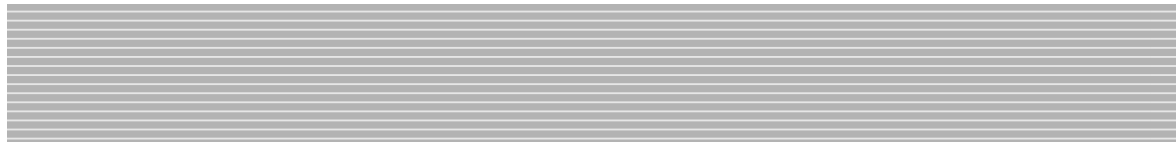

- 1
- 2
- 3
- 4
- 5
- 6
- 7
- 8
- 9
- 10
- 11

UART Communication Format

Commands, parameters and data are all transmitted in ASCII code.

Function	Command	Parameter	Data	Comments
Auto Focus	AF	0	■ ■	
Focus adjustment	FO	+ (NEAR) - (FAR) 0 (STOP)	■ ■	
Zoom adjustment	ZO	+ (TELE) - (WIDE) 0 (STOP)	■ ■	
Iris adjustment	IR	+ (OPEN) - (CLOSE) 0 (STOP) 1 (AUTO) 2 (MANUAL)	■ ■	
Lamp	PL	0 (OFF) 1 (ON)	■ ■	
Posi/Nega	NP	0 (POS) 1 (NEGA)	■ ■	
Color/B&W	CB	0 (COLOR) 1 (B&W)	■ ■	
Pointer display	PO	0 (OFF) 1 (ON)	■ ■	
Magnified image move	PM	0 (STOP) 1 (→) 2 (←) 3 (↑) 4 (↓) 5 (↗) 6 (↖) 7 (↘) 8 (↙)	■ ■	<ul style="list-style-type: none"> When the pointer is ON: The pointer moves. When the image magnification is ON.: The magnified image moves.
Digital Magnification	MA	0 (OFF) 1 (ON)	■ ■	
Pause	FZ	0 (OFF) 1 (ON)	■ ■	
γ adjustment	GN	0 (γ = 1.0) 1 (γ = 0.9) 2 (γ = 0.8) 3 (γ = 0.7) 4 (γ = 0.6) 5 (γ = 0.5) 6 (γ = 0.4) 7 (γ = 0.3)	■ ■	
Image Rotation	RO	0 (0°) 1 (90°) 2 (180°) 3 (270°)	■ ■	
Aperture selection	AP	0 (OFF) 1 (ON)	■ ■	
White Balance selection	AW	0 (OFF) 1 (AUTO) 2 (ONE-PUSH)	■ ■	

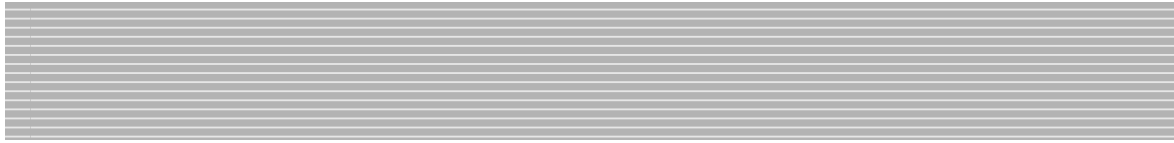

Function	Command	Parameter	Data	Comments
F.A.M. selection	CL	0 (OFF) 1 (ON)	■ ■	
Image Store	IS	1 2 3 4 5 6 7 8	■ ■	
Image Read	IC	1 2 3 4 5 6 7 8	■ ■	
Image Switch	AV	0	■ ■	• To finish the IMAGE CALL mode and go back to the normal camera image.
Contrast	CT	0 (OFF) 1 (ON)	■ ■	
Local Lockout	LL	0 (OFF) 1 (ON)	■ ■	
Default	DF	0	■ ■	
Status request	QS	0 2 7 8	■ ■	
Rom version	QR	0	■ ■	
ACK check	SA	0 (OFF) 1 (ON)	■ ■	
CR addition	SC	0 (OFF) 1 (ON)	■ ■	
Power Supply Off Timer	PW	0 (OFF) 1 (1 hour) 2 (2 hours) 3 (3 hours) 4 (4 hours) 5 (5 hours) 6 (6 hours) 7 (7 hours) 8 (8 hours)	■ ■	
Power Supply	DN	0 (OFF) 1 (ON)	■ ■	

- 1
- 2
- 3
- 4
- 5
- 6
- 7
- 8**
- 9
- 10
- 11



"■ ■" in the data column means that the SPACE [20H] should be transmitted twice.

9 REPLACING THE LAMP

1

Replacing the Lamp

2

The lamp that is installed in the product has a certain life span. When the lamp is used for a long period, the lamp light may become dark or the lamp may go off due to the end of its life. (The life of the lamp varies according to the utilization condition.) In this case, replace the lamp.

3

◆ How to replace the lamp

4



WARNING

- Use JR12V50W AKM/5EZ-1 manufactured by Phillips for replacement. Other lamps may blow out or cause fire if used.

5



CAUTION

- The lamp is very hot immediately after use. Direct contact with the lamp or lamp cover will cause burns. Make sure that lamp is thoroughly cooled off (30 minutes or more) before replacing the lamp.
- Replacement of the lamp requires a work done at a high location. Take care not to cause accident.

6

1. Turn OFF the Power Supply Switch.

7

2. Remove the power cord.

8

3. Wait until the lamp is thoroughly cooled off.

9

4. Remove the lamp cover.

- Loosen the fixing screws and displace the lamp cover in the arrow direction. (Fig. 1)
- Turn the lamp cover around the fixing screw. (Fig. 2)

10

5. Replace the lamp.

- Rotate the lamp and install a new lamp.

11

6. Install the lamp cover.

- Lamp cover shall be installed in sequence reverse to its removal.

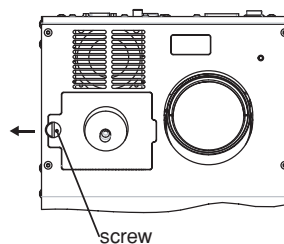

(Fig. 1)

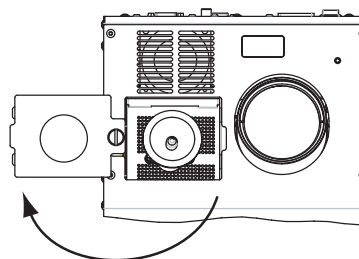

(Fig. 2)

REQUEST

Since the lamp is made of glass, do not touch the glass surface with bare hands, apply a strong impact, or scratch the surface.

10 TROUBLESHOOTING HINTS

Symptoms and Confirmation

Check the following items. If any abnormality is found, consult the seller or our branch/office in your area.

Symptom	Possible cause / countermeasure
No image on TV monitor.	<ul style="list-style-type: none"> • Cable is not properly connected to the video-in terminal of monitor. • The power cord is disconnected from the wall AC outlet. • The plug is disconnected from the power cord receptacle of this product. • The power switch is not turned ON. • Zoom is set at TELE to display only white/black part of the material. • The power switch is turned ON immediately after it is turned OFF. In this case, this product may not start. Wait several seconds after turning OFF the power switch, and then turn ON the power switch.
Out of focus	<ul style="list-style-type: none"> • The object is too close to the lens. Check if the object is not placed at a distance shorter than 1.3m (51.2 in.) from the unit. • FOCUS is set at the extreme position of WIDE and the picture is zoomed to TELE. FOCUS at the extreme position of TELE and zoom the picture to WIDE. • Focusing is sometimes difficult in the AUTO FOCUS mode.
Image oscillates.	<ul style="list-style-type: none"> • If image oscillates widely at TELE position or in the digital magnification, vibration of the building could affect the event. By pushing the [PAUSE] button on the wireless remote control, image oscillation is alleviated by displaying still image.
Video output image is disarrayed.	<ul style="list-style-type: none"> • Is the video output type set to PAL? If this product which is set to PAL is connected to the monitor specially designed for NTSC, the video image may not be output normally, in which the image is disarrayed, or becomes black and white. Switch the video output type by referring to P. 9 "DIP Switches."
Image is too dark.	<ul style="list-style-type: none"> • The intensity of illumination is not sufficient. Turn ON the lamp by pressing the [LAMP] button on the wireless remote control. • If the distance from this product to a manuscript is long, illuminate the surface of specimen brighter by using external lighting. • Is the iris adjusted to "Close" side? Adjust the iris to "Open" side.
The image is striped.	<ul style="list-style-type: none"> • This may be interference fringes between dots of printed matter and TV scanning lines or CCD pixels, which may be mitigated by changing the projection range. • When using an LCD projector, vertical stripes may appear on the screen. This may be mitigated by manually adjusting the dot clock frequency on the projector side (refer to P. 15).
Brightness tone is out of order.	<ul style="list-style-type: none"> • This may be mitigated by switching the Gamma setting.

1

2

3

4

5

6

7

8

9

10

11

11 SPECIFICATIONS

1

2

3

4

5

6

7

8

9

10

11

■ General

Item	Specifications		
Power source	AC100 - 240V 50Hz/60Hz		
Rated current	1.2 - 0.6A		
Dimensions (W × D × H)	226mm × 226mm × 239mm (8.9 × 8.9 × 9.4 in.)		
Weight	6.5 kg (14.3 lbs.) (main body only)		
Output terminal	RGB output	Mini DSUB 15P connector, female	×1
	Composite Video output	RCA pin jack/75Ω unbalanced (NTSC/PAL)	×1
	S-Video output	Mini DIN 4P connector/75Ω unbalanced (NTSC/PAL)	×1
Ext. control terminal	RS-232C	DSUB 9P connector, male	×1
	Mouse	Mini DIN 6P connector, female	×1
	USB	Type B receptacle	×1

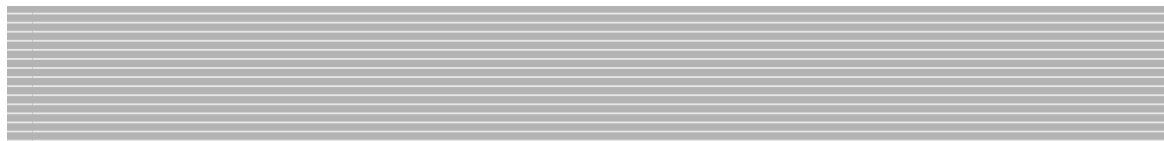

■ Camera

Item	Specifications
Lens	f = 14.2 – 170mm (12 - time zoom), F2.6 – 2.7
Frame rate	20 frames / sec
Shooting area(H × V) (Projection → photographing distance: 2m(78.7in))	662mm × 511mm (26.0 × 20.1 in.) max. 53mm × 41mm (2.1 × 1.6 in.) min.
Limit of focus adjustment	Distance from the unit to the text (object of shooting): 1.3 m ~ ∞.
Zooming	Electromotive (with double speed function)
Focusing	Auto / Manual
Iris	Auto (level adjustable) Manual (RS-232C)
Image pick-up device	1/3" CCD
Total pixels	1077(H) × 788(V), 850,000 pixels
Effective pixels	1034(H) × 779(V)
Sync. system	Internal sync.
Resolution	Analog RGB output : Horizontal 600TV lines or more; Vertical 600TV lines or more Video output : Horizontal 400 TV lines or more
Analog RGB output	0.7V (p-p) 75Ω unbalanced, synchronization signal, positive polarity Signal frequency XGA: Horizontal frequency 48.363 kHz; Vertical frequency 60.004 Hz (1024 × 768 at 60 Hz); Compliant with VESA
Composite Video output	NTSC/PAL
S-Video output	NTSC/PAL
White Balance	Full auto / One-push / Manual
Video output selection	Provided (NTSC / PAL)
Posi/Nega conversion	Provided
Color/B&W selection	Provided
Image Rotation	Provided (0° / 90° / 180° / 270°)
Contrast	Provided
Gamma selection	Provided (1.0 / 0.9 / 0.8 / 0.7 / 0.6 / 0.5 / 0.4 / 0.3)
Aperture selection	Provided
Pause	Provided
Digital magnification	Provided (double, can be scrolled)
Pointer	Controllable (color selectable)
F.A.M. selection	Provided

■ Lighting

Item	Specifications
Lamp	Halogen lamp 12V 50W (model: JR12V50W AKM/5EZ-1 manufactured by Phillips)

1

2

3

4

5

6

7

8

9

10

11

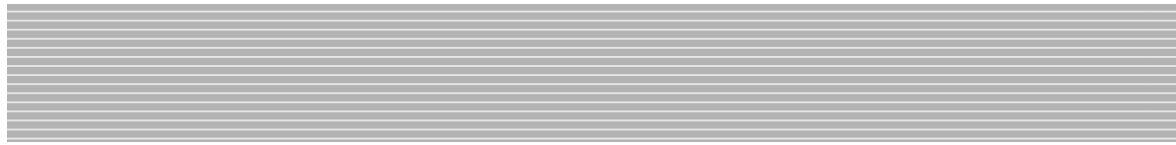

- 1
- 2
- 3
- 4
- 5
- 6
- 7
- 8
- 9
- 10
- 11

■ Supplied Accessories

Name	Quantity
Power cord (2.5m)	1
Video cable (RCA pin connector) (3 m)	1
S-Video cable (Mini DIN 4P connector) (2 m)	1
Infrared wireless remote controller (RCW-C1000)	1
Batteries (Type R03, AAA)	2
Analog RGB cable (DSUB 15P connector) (2 m)	1
Analog RGB cable (BNC connector) (1.8 m)	1
Instruction manual	1
Installation manual	1
Warranty card	1
Scroll mouse	1
USB cable (1.8m)	1
Utility Software CD-ROM	1
Utility Software Installation Manual	1
C. Mounting fitting	1
Attaching screw (M4x10)	3
Attaching screw (M5x10)	4

■ Optional parts (to be purchased separately)

- Halogen lamp (JR12V50W AKM/5EZ-1)
- Ceiling-mounting fitting VB-1000



For the RCA pin, use a pin plug compliant with RC-6703.



The above specifications are subject to change without notice.

Trademark Acknowledgements

VESA is a registered trademark of Video Electronics Standards Association.

VGA, SVGA, XGA and SXGA are trademarks or registered trademarks of International Business Machines Corporation.

ELMO and **ELMO**, VISUAL PRESENTER, FOCUSFREE are trademarks of ELMO Co., Ltd.

WARNING

Unauthorized recording of copyrighted slide films, materials, photographs, etc. may infringe on the rights of copyright owners and be contrary to copyright laws.



ELMO CO., LTD.

6-14, Meizen-cho, Mizuho-ku,
Nagoya, 467-8567, Japan

OVERSEAS SUBSIDIARY COMPANIES

- U.S.A.** **ELMO Mfg. Corp.**
1478 Old Country Road, Plainview, NY 11803-5034
Tel:(516)501-1400 Fax:(516)501-0429
E-mail: elmo@elmousa.com
Web: <http://www.elmousa.com/>
- Canada** **ELMO Canada Mfg. Corp.**
44 West Drive, Brampton, Ontario L6T 3T6
Tel:(905)453-7880 Fax:(905)453-2391
E-mail: info@elmocanada.com
Web: <http://www.elmocanada.com/>
- Germany** **ELMO (Europe) G.m.b.H.**
Neanderstr. 18, 40233 Düsseldorf
Tel:(0211)376051 Fax:(0211)376630
E-mail: elmoeurope@AOL.com
Web: <http://www.elmo.de/>